

Parts List			
ITEM	QTY	PART No.	DESCRIPTION
1	1	BA8505	20 Inch Suction Anchor Vent Valve
2	1	BA9484	20 Inch Suction Anchor Vent Valve 2 End wBarrier Ring

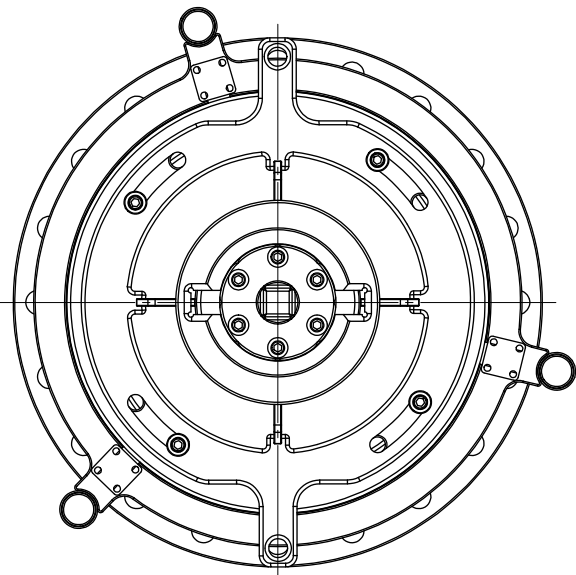
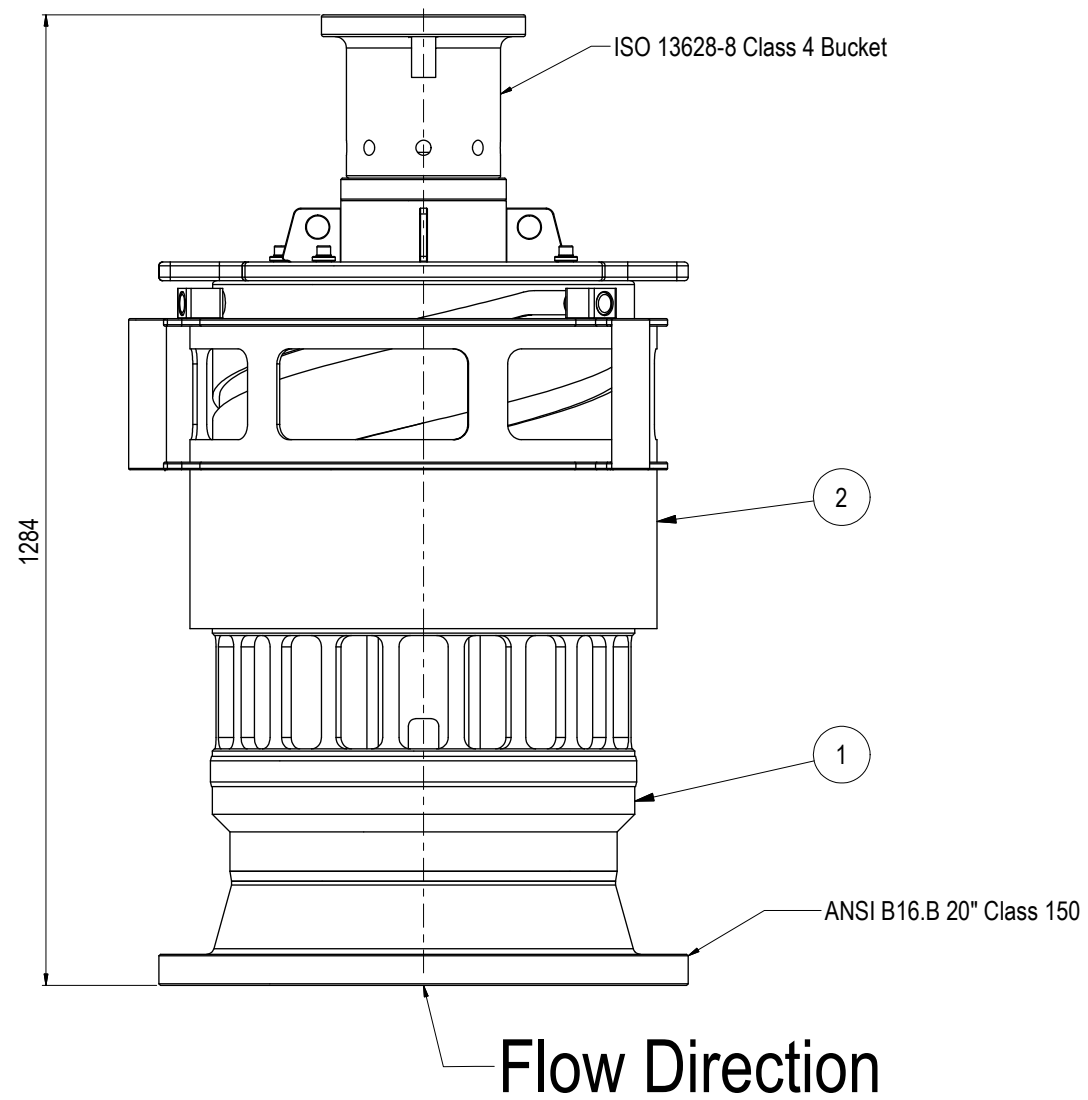
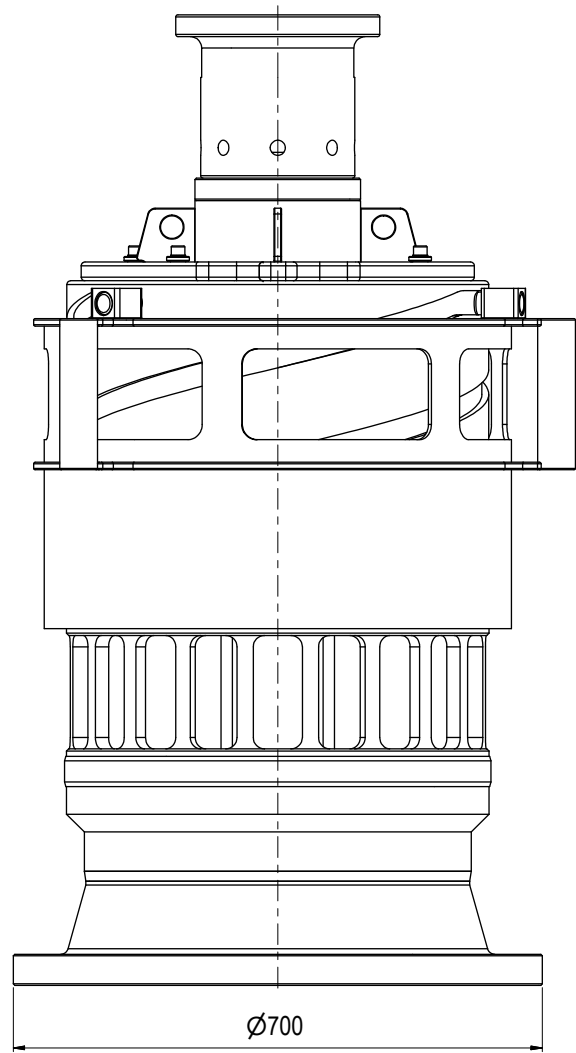

NOTE: 1
DESIGN CODE:
N/A

NOTE: 2
TECHNICAL CLASSIFICATION:
Article Type: 007-Valves
Main Group: 7.01. One Way Valves
Intermediate Group: 7.39.00. Generic
Sub Group: 7.39.160.0. Generic

NOTE: 3
INTERFACE INFORMATION:
Pressure Rating Bar: 15
Material: N/A
Weight: 519,5 kg
Volume: 92,75 dm³
Surface Area: 116288 cm²
Hydraulic: N/A
Mechanical: ANSI B16.B 20" Class 150
Electrical: N/A
Com. & Protocol: N/A

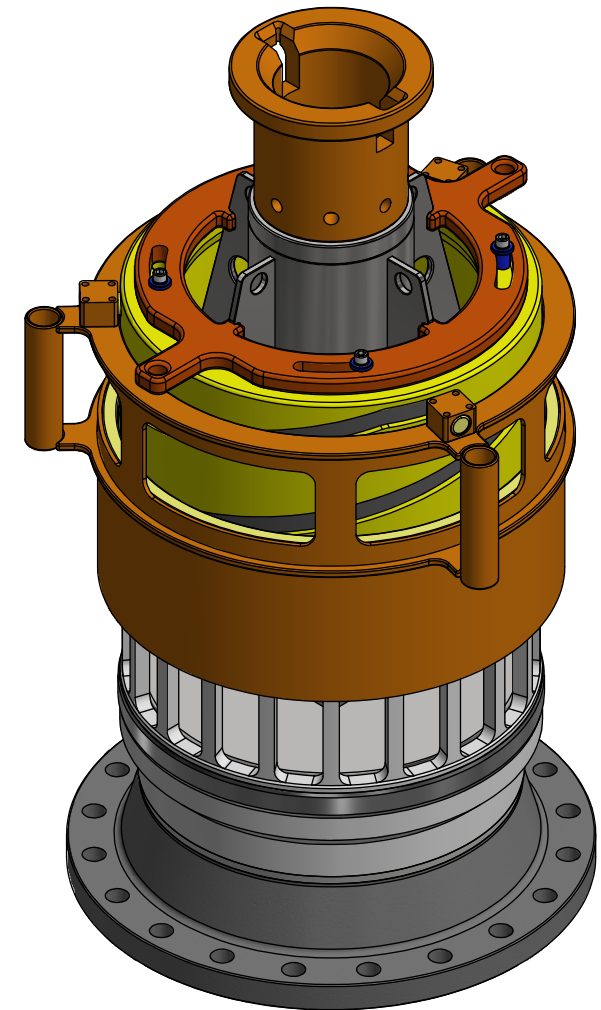

FOR INFORMATION ONLY

Rev.	Date	Reason for issue	Revision change	Made	Chk'd	Appr.
02	9.1.2017	2-IFT (Issued For Tender)		WTJ	LGH	WTJ
01	9.12.2016	2-IFT (Issued for Tender)		WTJ	N/A	N/A



Dwg Scale:	NTS
Dwg Proj:	
Dwg Format:	A3

Drawing title:	20 Inch Suction Anchor Vent Valve wBarrier Ring	
Drawing number:	BA9431	Rev: 02